

FITTING INSTRUCTION

Clamp mark in acc. with		Cables joining
ISO	PN	
1	L	Left directional lights
2	+	Rear fog lights
3	31	Ground
4	R	Right directional lights
5	58R	Right side parking lights
6	54	Stoplights
7	58L	Left side parking lights

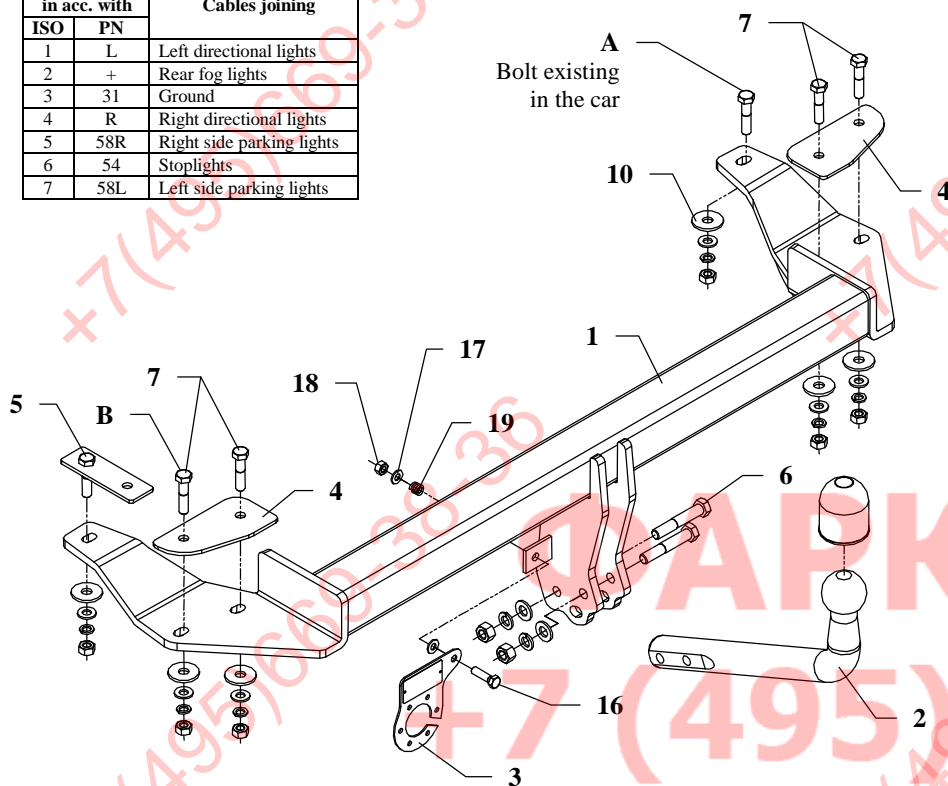

This towbar is designed to assembly in following cars: **AUDI A8, S8, QUATTRO, TDI**, produced since 1997 till 2001, catalogue no. **A17** and is prepared to tow trailers max total weight **2350 kg** and max vertical load **75 kg**.

From manufacturer

Thank you for buying our product. Their reliability has been confirmed in many tests. Reliability of towbar depends also on correct assembly and right operation. For this reasons we kindly ask to read carefully this instruction and apply to hints.

The towbar should be install in points described by a car producer.

The instruction of the assembly

1. Disassemble the bumper.
2. Disassemble original towing eye from the right, rear side of the car (not used any more).
3. Disassemble rear handle of the muffler fastener.
4. Disassemble handle of bumper fastener (left side), put bolt on the jib (pos. 5) (place it in original hole as existing bolt (pos. A) on the right side).
5. Put main bar of the towbar (pos. 1) in this way, so towbar holes agree with holes in chassis and fix as show on the figure (use washers pos. 10).
6. Fix bracket of muffler fastener (before install remove bolt from it), this will make possible to fix above mentioned to bolt (pos. B).
7. Reinstall the bumper.
8. Fix tow-ball (pos. 2) and socket plate (pos. 3) using bolts M12x70mm (pos. 6) from accessories.
9. Fix the socket plate (pos. 3) as shown on the drawing.
10. Tighten all bolts according to the torque shown in the table.
11. Connect electric wires of 7-poles socket according to the instruction of the car. (Recommend to make at authorized service station).
12. Complete paint layer damaged during installation.

Torque settings for nuts and bolts (8,8):	
M 8 - 25 Nm	M 10 - 55 Nm
M 12 - 85 Nm	M 14 - 135 Nm











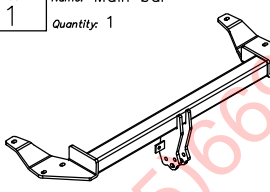
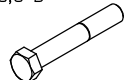





NOTE

After install the towbar you should get adequate note in registration book (at authorised service station). The car should be equipped with:

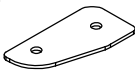
- Indicators
- Tow mirrors

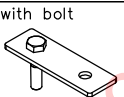
After 1000km check all bolts and nuts. The ball of towbar must be always kept clear and conserve with a grease.

Towbar accessories:

Pos. 1 Name: Main bar Quantity: 1 	Pos. 6 Name: Bolt 8,8 B Quantity: 2 Dim.: M12x70mm 	Pos. 13 Name: Spring washer Quantity: 2 Dim.: Ø 12,2 mm 
	Pos. 7 Name: Bolt 8,8 B Quantity: 4 Dim.: M10x45mm 	Pos. 14 Name: Spring washer Quantity: 6 Dim.: Ø 10,2 mm 
Pos. 2 Name: Tow ball Quantity: 1 	Pos. 8 Name: Nut 8 B Quantity: 2 Dim.: M12 	Pos. 15 Name: Ball cover Quantity: 1 
Pos. 3 Name: Socket plate Quantity: 1 	Pos. 9 Name: Nut 8 B Quantity: 6 Dim.: M10 	Pos. 16 Name: Bolt 8,8 B Quantity: 1 Dim.: M8x30mm 
Pos. 4 Name: Plate Quantity: 2 	Pos. 10 Name: Washer Quantity: 6 Dim.: Ø35xØ12x3mm 	Pos. 17 Name: Plain washer Quantity: 2 Dim.: Ø 8,5 mm 
Pos. 5 Name: Plate with bolt Quantity: 1 	Pos. 11 Name: Plain washer Quantity: 2 Dim.: Ø 13 mm 	Pos. 18 Name: Nut 8 B Quantity: 1 Dim.: M8 
	Pos. 12 Name: Plain washer Quantity: 6 Dim.: Ø 10,5 mm 	Pos. 19 Name: Spring Quantity: 1 



PPUH AUTO-HAK S.J.

Produkcja Haków Holowniczych
Henryk & Zbigniew Nejman
76-200 SŁUPSK ul. Stoneczna 16K
tel/fax (059) 8-414-414; 8-414-413
E-mail: office@autohak.com.pl
www.autohak.com.pl

Towing hitch (without electrical set)

Class: **A50-X** Cat. no. **A17**

Designed for:

Manufacturer: **AUDI**

Model: **A8, S8, QUATTRO, TDI**

produced since 1997 till 2001

Technical data:

D-value: 12,5 kN

maximum trailer weight: **2350 kg**

maximum vertical cup load: **75 kg**

Approval number acc. to regulations EKG/ONZ 55.01: E20-55R-01 1798

Foreword

This towbar is designed according to rules of safety traffic regulations. The towing hitch is a safety component and can be install only by qualified personnel. Any alteration or conversion of the towing hitch is prohibited and would lead to cancellation of design certification. Remove insulating compound and underseal from vehicle (if present) in the area of the matting surfaces of the towing hitch. The vehicle manufacturer's specifications regarding trailer load and max. vertical cup load are decisive for driving whereat values for the towing hitch cannot be exceeded.

D-value formula:

$$\frac{\text{Max trailer weight [kg]} \times \text{Max vehicle weight [kg]}}{\text{Max trailer weight [kg]} + \text{Max vehicle weight [kg]}} \times \frac{9,81}{1000} = D \text{ [kN]}$$